

Application

Schneider Electric DuraDrive overshaft actuators are designed to provide an economical and reliable solution for many overshaft damper and Schneider Electric DuraLynx ball valve requirements. All products accommodate shaft sizes up to 1/2" (13 mm) in diameter.

Spring return models provide 30 in-lb (3.4 N-m) of torque in either two position, floating or proportional control. Non-spring return models provide either 35 in-lb (4 N-m) or 70 in-lb (8 N-m) in either floating or proportional control.

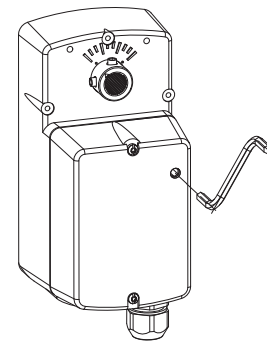

MA4D-xxxx



Features

- Two position models controlled by SPST controller
- Floating models controlled by SPDT floating controllers
- Proportional models controlled by 0 to 3 Vdc, 6 to 9 Vdc, 0 to 10 Vdc, 2 to 10 Vdc or 4 to 20 mAdc with the addition of a 500 ohm resistor. Control function direct/reverse action is jumper selectable
- Spring return models provide 30 in-lb (3.4 N-m) of torque
- Non-spring return models supply 35 in-lb (4 N-m) or 70 in-lb (8 N-m) of torque
- Polymer housing rated for NEMA 2/IP54
- Overload protection throughout stroke
- Floating and proportional models automatically adjust the input span to match the damper/valve travel
- Compact size to allow installation in limited space
- Manual override to allow positioning of dampers and valves
- Directly mounts to 1/2 to 3" Schneider Electric DuraLynx ball valves
- Polymer housing rated for plenum use

Applicable Literature

F-Number	Description	Audience	Purpose
F-25097	Accessory AM-714 General Instructions	<ul style="list-style-type: none"> – Application Engineers – Installers – Sales Personnel – Service Personnel – Start-up Technicians 	Provides step-by-step installation procedures.
F-26080	EN-205 Water System Guidelines		Describes Schneider Electric approved water treatment practices.
F-26895	Accessories AM-703, AM-704, AM-705, AM-706, AM-708 General Instructions		Provides step-by-step installation procedures.
F-26899	Accessory AM-756 General Instructions		
F-27086	Vx-2x13-5xx-9-xx Series, VB-2x13-500-9-xx Series Schneider Electric DuraLynx™ Ball Valve Assemblies Ball Valve Body/Linkage Selection Guide		Provides features, specifications, mounting dimensions, and other criteria useful in the selection of ball valve assemblies.

SPECIFICATIONS

Actuator Inputs

Control Signal: See Table-1 thru 4 for actuator models and control types.

Power Input: See Table-1 thru 4. All 24 Vac circuits are Class 2. All circuits 30 Vac and above are Class 1.

Connections: 3 ft (91 cm) appliance or plenum cables, enclosure accepts 1/2" (13 mm) conduit connector. For M20 Metric conduit, use AM-756 adaptor.

Actuator Outputs

Electrical:

Position Feedback Voltage (proportional or floating only),

For voltage ranges, the feedback signal is the same range as the input signal. The 4 to 20 mA current range and floating actuators have a 2 to 10 Vdc feedback signal. The feedback signal can supply up to 0.5 mA to operate up to four additional slave actuators.

Mechanical:

Timing, See Figure-1 to Figure-4.

Travel, 93° nominal.

Manual Override, Allows positioning of damper or valve using manual crank.

RA/DA Jumper, Permits reverse acting/direct acting control (MS4D models only).

Environment:

Ambient Temperature Limits,

Shipping & Storage, -40 to 160 °F (-40 to 71 °C).

Operating, -22 to 140 °F (-30 to 60 °C).

Humidity: 15 to 95% RH, non-condensing.

Location: NEMA 1. NEMA 2, UL Type 2 (IEC IP54) with customer supplied water tight conduit connectors. Enclosure is air plenum rated.

Agency Listings

UL 873: Underwriters Laboratories (File #E9429 Category Temperature-Indicating and Regulating Equipment).

CUL: UL Listed for use in Canada by Underwriters Laboratories. Canadian Standards C22.2 No. 24-93.

European Community: EMC Directive (89/336/EEC). Low Voltage Directive (72/23/EEC). This product fits in Installation Category (Overvoltage Category) II per EN 61010-1.

Australia: This product meets requirements to bear the C-Tick Mark according to the terms specified by the Communications Authority under the Radiocommunications Act 1992.

Note: All performance specifications are nominal and conform to acceptable industry standards. For applications at conditions beyond these specifications, consult Schneider Electric. Schneider Electric shall not be liable for damages resulting from misapplication or misuse of its products.

Table-1 30 in-lb (3.4 N-m) Spring Return CCW Actuators (Viewed from cover side).

Part Number	Control Signal	Voltage	Wiring System	Actuator Power Input				Approximate Timing ^a in Sec. @ 70 °F (21 °C)	
				Running			Holding	Powered	Spring Return (CCW)
				50/60 Hz		DC Amps	50/60 Hz		
				VA	W		W		
MA4D-7033-000	2 Position SPST	24 VAC +/-20% or 20-30 Vdc	Appliance Wire	5.1	3.6	0.14	1.3	56	23
MA4D-7033-100			Plenum Cable						
MA4D-7030-000		120 Vac ± 10% 50/60 Hz	Appliance Wire	7.8	5.0	—	2.5		
MA4D-7031-000			230 Va ± 10% 50/60 Hz	7.2	5.2	—	2.4		
MF4D-7033-000	Floating	24 Vac +/-20% or 20-30 Vdc	Appliance Wire	6.8	4.2	0.15	1.9	85	21
MF4D-7033-100			Plenum Cable						
MS4D-7033-000	2 to 10 Vdc ^b Proportional		Appliance Wire	6.1	3.4	0.12	1.4		
MS4D-7033-100			Plenum Cable						
MS4D-7033-020	0 to 3 Vdc Proportional		Appliance Wire	6.1	3.4	0.12	1.4		
MS4D-7033-120			Plenum Cable						
MS4D-7033-030	6 to 9 Vdc Proportional		Appliance Wire	6.1	3.4	0.12	1.4		
MS4D-7033-130			Plenum Cable						
MS4D-7033-050	0 to 10 Vdc Proportional		Appliance Wire	6.1	3.4	0.12	1.4		
MS4D-7033-150			Plenum Cable						
MS4D-7033-060	4 to 20 mAdc Proportional		Appliance Wire	6.1	3.4	0.12	1.4		
MS4D-7033-160			Plenum Cable						

^a Timing was measured with no load applied to actuator.

^b 4 to 20 mAdc with field-installed 500 ohm resistor.

Table-2 30 in-lb (3.4 N-m) Spring Return CW Actuators (Viewed from cover side).

Part Number	Control Signal	Voltage	Wiring System	Actuator Power Input				Approximate Timing ^a in Sec. @ 70 F (21° C)	
				Running			Holding	Powered	Spring Return (CW)
				50/60 Hz		DC Amps	50/60 Hz		
				VA	W		W		
MA4D-8033-000	2 Position SPST	24 VAC +/-20% or 20-30 Vdc	Appliance Wire	5.1	3.6	0.14	1.3	56	23
MA4D-8033-100			Plenum Cable						
MA4D-8030-000		120 Vac ± 10% 50/60 Hz	Appliance Wire	7.8	5.0	—	2.5		
MA4D-8031-000			230 Vac ± 10% 50/60 Hz	7.2	5.2	—	2.4		
MF4D-8033-000	Floating	24 Vac +/-20% or 20-30 Vdc	Appliance Wire	6.8	4.2	0.15	1.9	85	21
MF4D-8033-100			Plenum Cable						
MS4D-8033-000	2 to 10 Vdc ^b Proportional		Appliance Wire	6.1	3.4	0.12	1.4		
MS4D-8033-100			Plenum Cable						
MS4D-8033-020	0 to 3 Vdc Proportional		Appliance Wire	6.1	3.4	0.12	1.4		
MS4D-8033-120			Plenum Cable						
MS4D-8033-030	6 to 9 Vdc Proportional		Appliance Wire	6.1	3.4	0.12	1.4		
MS4D-8033-130			Plenum Cable						
MS4D-8033-050	0 to 10 Vdc Proportional		Appliance Wire	6.1	3.4	0.12	1.4		
MS4D-8033-150			Plenum Cable						
MS4D-8033-060	4 to 20 mAdc Proportional		Appliance Wire	6.1	3.4	0.12	1.4		
MS4D-8033-160			Plenum Cable						

^a Timing was measured with no load applied to actuator.

^b 4 to 20 mAdc with field-installed 500 ohm resistor.

Table-3 Non-Spring Return 35 in-lb (4 N-m) Actuators.

Part Number	Control Signal	Voltage	Wiring System	Actuator Power Input				Approximate Timing ^a in Sec. @ 70 °F (21 °C)
				Running			Holding	
				50/60 Hz		DC Amps	50/60 Hz	
				VA	W		W	
MF4D-6043-000	Floating	24 VAC +/-20% or 20-30 Vdc	Appliance Wire	4.4	2.7	0.1	1.7	85
MF4D-6043-100			Plenum Cable					
MS4D-6043-000	2 to 10 Vdc ^b Proportional		Appliance Wire	4.2	2.2	0.08	1.2	
MS4D-6043-100			Plenum Cable					
MS4D-6043-020	0 to 3 Vdc Proportional		Appliance Wire	4.2	2.2	0.08	1.2	
MS4D-6043-120			Plenum Cable					
MS4D-6043-030	6 to 9 Vdc Proportional		Appliance Wire	4.2	2.2	0.08	1.2	
MS4D-6043-130			Plenum Cable					
MS4D-6043-050	0 to 10 Vdc Proportional		Appliance Wire	4.2	2.2	0.08	1.2	
MS4D-6043-150			Plenum Cable					
MS4D-6043-060	4 to 20 mA ^c Proportional		Appliance Wire	4.2	2.2	0.08	1.2	
MS4D-6043-160			Plenum Cable					

^a Timing was measured with no load applied to actuator.

^b 4 to 20 mA^c with field-installed 500 ohm resistor.

Table-4 Non-Spring Return 70 in-lb (8 N-m) Actuators.

Part Number	Control Signal	Voltage	Wiring System	Actuator Power Input				Approximate Timing ^a in Sec. @ 70 °F (21 °C)
				Running			Holding	
				50/60 Hz		DC Amps	50/60 Hz	
				VA	W		W	
MF4D-6083-000	Floating	24 VAC +/-20% or 20-30 Vdc	Appliance Wire	5.9	3.6	0.13	1.6	85
MF4D-6083-100			Plenum Cable					
MS4D-6083-000	2 to 10 Vdc ^b Proportional		Appliance Wire	5.2	2.7	0.10	1.4	
MS4D-6083-100			Plenum Cable					
MS4D-6083-020	0 to 3 Vdc Proportional		Appliance Wire	5.2	2.7	0.10	1.4	
MS4D-6083-120			Plenum Cable					
MS4D-6083-030	6 to 9 Vdc Proportional		Appliance Wire	5.2	2.7	0.10	1.4	
MS4D-6083-130			Plenum Cable					
MS4D-6083-050	0 to 10 Vdc Proportional		Appliance Wire	5.2	2.7	0.10	1.4	
MS4D-6083-150			Plenum Cable					
MS4D-6083-060	4 to 20 mA ^c Proportional		Appliance Wire	5.2	2.7	0.10	1.4	
MS4D-6083-160			Plenum Cable					

^a Timing was measured with no load applied to actuator.

^b 4 to 20 mA^c with field-installed 500 ohm resistor.

Ball Valve Close-Off Pressures: For close-off pressure ratings on Schneider Electric Duralynx ball valves, consult Schneider Electric Duralynx Ball Valve Assemblies Ball Valve Body/Linkage Selection Guide F-27086.

ACCESSORIES

- AM-763 1/8" Hexcrank for manual override
- AM-756 Metric Conduit Adapter M20 x 1.5 to 1/2" NPT
- AM-771 Crank Arm and bracket kit
- AM-772 Bracket for reverse mounting
- AM-714 Weathershield Kit

MS4D-xxx3-xxx

- AM-703 Input rescaling module, adjust signals to 2-10 Vac, zero and span adjust
- AM-704 Interface, pulse width modulation (PWM)
- AM-705 Positioner (NEMA 4 housing)
- AM-706 Min and/or manual positioner for flush panel mount
- AM-708 500 Ω resistor for 4 to 20 mA control signal

TYPICAL TWO POSITION CONTROL (wiring diagrams)

Figure-1 illustrates typical wiring diagrams for spring return **two-position MA4D-x03x-xxx** actuators.

See Tables 1-2 for model selection.

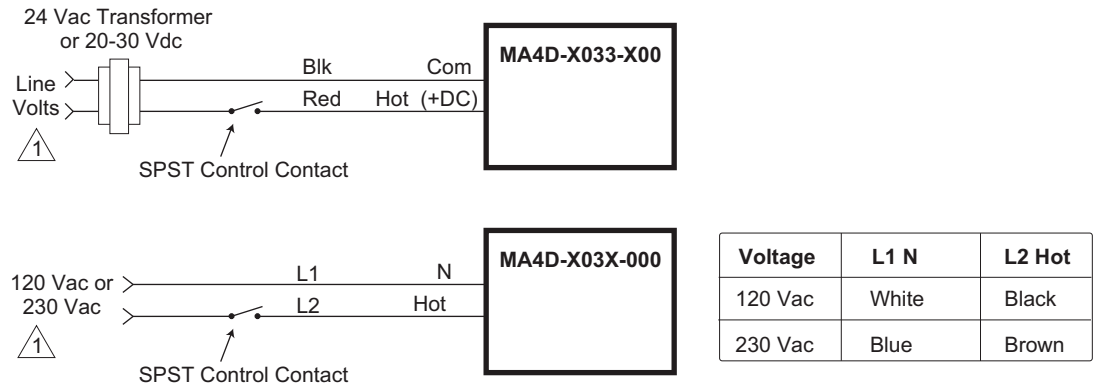

Figure-1 Typical Wiring Diagrams for Two Position Actuators.

TYPICAL FLOATING CONTROL (wiring diagrams)

Figure-2 through Figure-5 illustrate typical wiring diagrams for **floating MF4D-xxx3-x00** actuators. See Tables 1-4 for model selection.

Caution: This product contains a half-wave rectifier power supply and must not be powered off transformers used to power other devices utilizing non-isolated full-wave rectifier power supplies. Refer to *EN-206, Guidelines for Power Multiple Devices from a Common Transformer, F-26363* for detailed information.

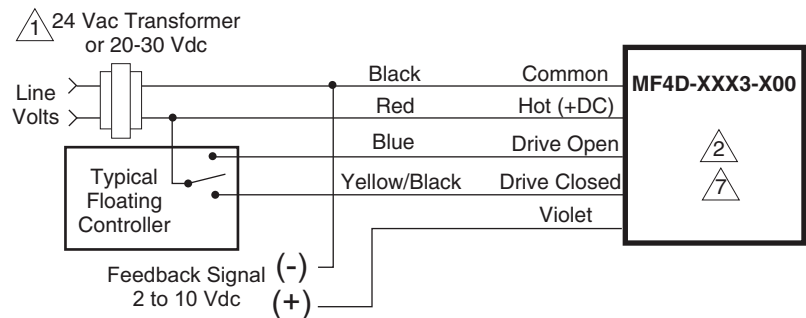

Figure-2 Floating Point Control.

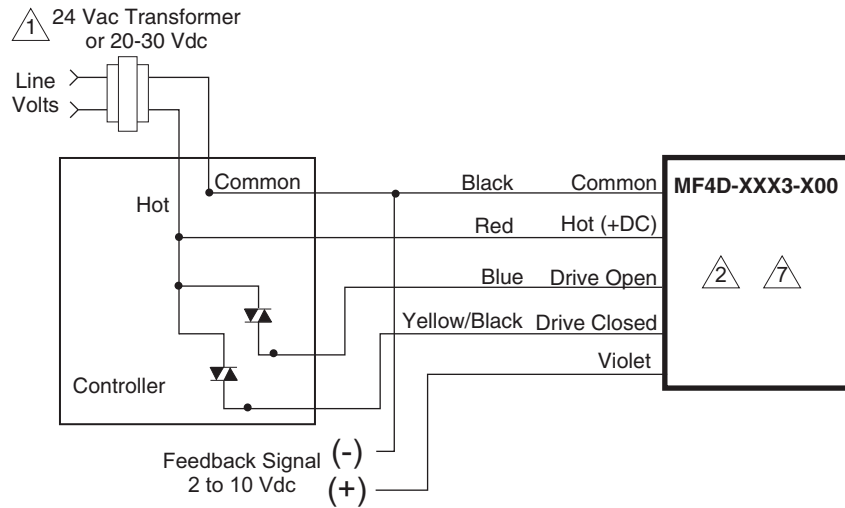

Figure-3 Triac Source.

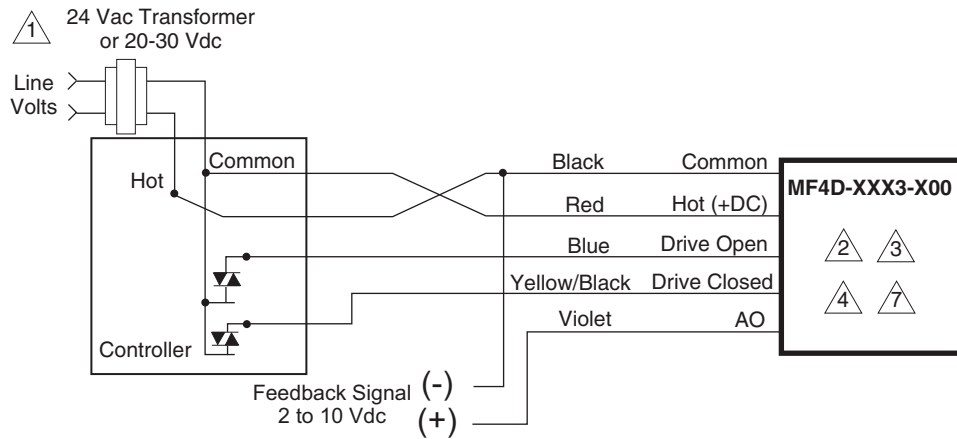

Figure-4 Triac Sink.

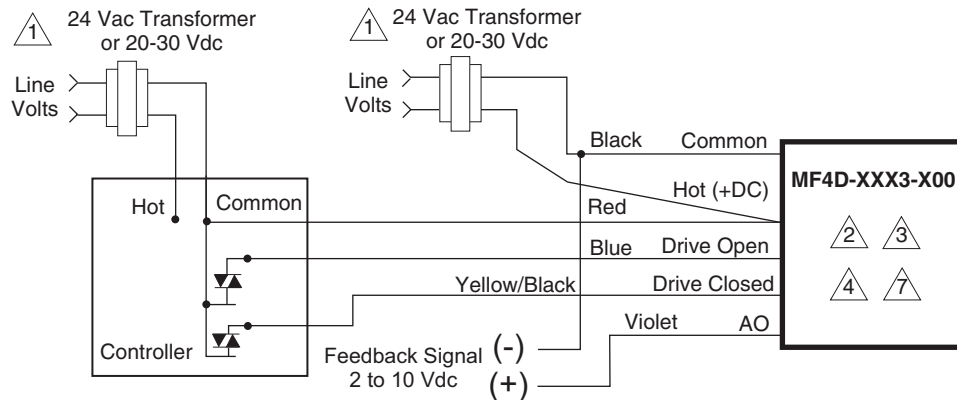

Figure-5 Triac Sink With Separate Transformers.

TYPICAL PROPORTIONAL CONTROL (wiring diagrams)

Figure-6 illustrates typical wiring diagrams for **proportional MS4D-xxx3-xx0** actuators. See Table-1 for model selection.

Caution: This product contains a half-wave rectifier power supply and must not be powered off transformers used to power other devices utilizing non-isolated full-wave rectifier power supplies. Refer to *EN-206, Guidelines for Powering Multiple Devices from a Common Transformer, F-26363* for detailed information.

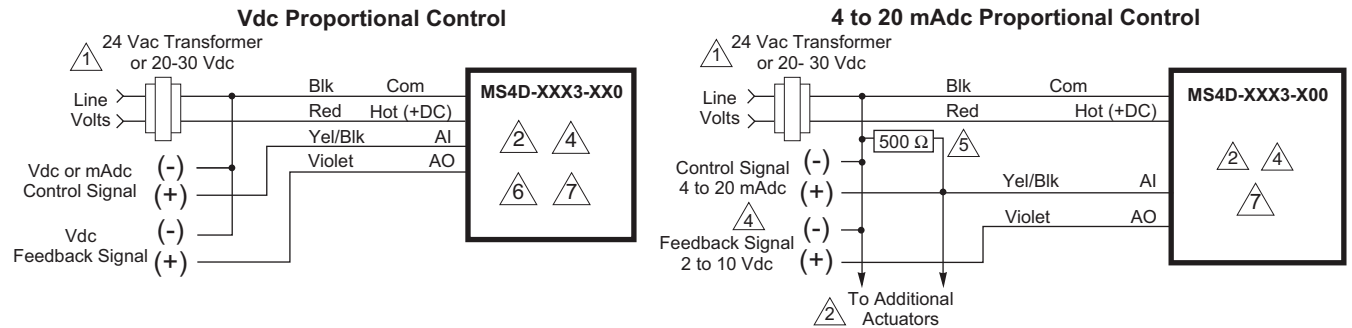

Figure-6 Typical Wiring Diagrams for Proportional Control 24 Vac Basic Models.

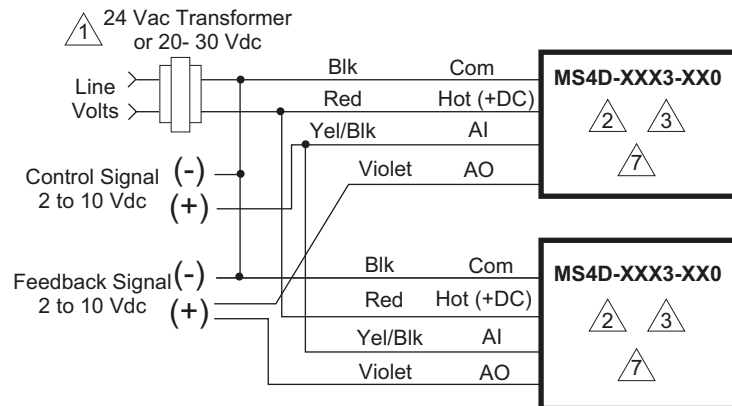

Figure-7 Typical Wiring Diagrams for Proportional Control 24 Vac Models Wired in Parallel.

- △1 Provide overload protection and disconnect as required.
- △2 Actuators may be wired in parallel. All actuator black wires are connected to the transformer common and all red wires are connected to the hot lead. Power consumption must be observed.
- △3 The Common connection from the actuator must be connected to the Hot connection of the controller. The actuator Hot must be connected to the controller Common.
- △4 If the controller uses a full-wave power supply and does not provide isolated outputs, a separate transformer is required.
- △5 A field-supplied 500 ohm resistor (AM-708) is required for this application.
- △6 On MS4D-XXX3-X60 (0-20 mAdc) models a 500 resistor is incorporated in the product. Do not use an external resistor.
- △7 Cable on some models contains more wires than are used in applications. Only those wires actually used are shown.

Figure-8 Triangle Notes for Wiring Diagrams.

INSTALLATION

Inspection

Inspect the package for damage. If damaged, notify the appropriate carrier immediately. If undamaged, open the package and inspect the device for obvious damage. Return damaged products.

Requirements

- Job wiring diagrams
- Appropriate accessories
- Installer must be a qualified, experienced technician
- 1/8" hex allen wrench (not provided)
- #8 Torx screwdriver (not provided)
- #8 sheet metal screws (2) (not provided)
- Appropriate drill bits (not provided)

Precautions



General

Warning:

- Electrical shock hazard! Disconnect the power supply (line power) before installation to prevent electric shock and equipment damage.
- Make all connections in accordance with the job wiring diagram and in accordance with national and local electrical codes. *Use copper conductors only.*
- Floating and Proportional Models: These products contain a half-wave rectifier power supply. They must not be powered with transformers that are used to power other devices utilizing non-isolated full-wave rectifier power supplies. Refer to EN-206, Guidelines For Powering Devices From A Common Transformer, F-26363 for detailed information.

Caution:

- Avoid electrical noise interference. Do not install near large contactors, electrical machinery, or welding equipment.
- Manual override to be used only when power is not applied to unit.
- When operating manual override (observe position indicator), back off 5° from full extended mechanical stop to ensure proper release.

Federal Communications Commission (FCC)

Note: This equipment has been tested and found to comply with the limits for a Class B digital device, pursuant to Part 15 of the FCC Rules. These limits are designed to provide reasonable protection against harmful interference in residential installations. This equipment generates, uses, and can radiate radio frequency energy and may cause harmful interference if not installed and used in accordance with the instructions. Even when instructions are followed, there is no guarantee that interference will not occur in a particular setting—Which can be determined by turning the equipment off and on—the user is encouraged to try to correct the interference by one or more of the following measures:

- Reorient or relocate the receiving antenna.
- Increase the separation between the equipment and receiver.
- Connect the equipment to an outlet on a circuit different from that to which the receiver is connected.
- Consult the dealer or an experienced radio/television technician for help.

Canadian Department of Communications (DOC)

Note: This Class B digital apparatus meets all requirements of the Canadian Interference-Causing Equipment Regulations.

Cet appareil numérique de la classe B respecte toutes les exigences du Règlement sur le matériel brouilleur du Canada.

European Standard EN 55022

Note: This is a Class B digital (European Classification) product. In a domestic environment this product may cause radio interference in which case the user may be required to take adequate measures.

Location

Caution: Avoid locations where excessive moisture, corrosive fumes, vibration, or explosive vapors are present.

Mounting

Changing Control Function (proportional units only)

These actuators are equipped with a jumper to control the function of the signal as received. See Figure-9. Factory setting is for direct acting (actuator moves away from normal position as signal increases). Remove cover to change jumper settings.

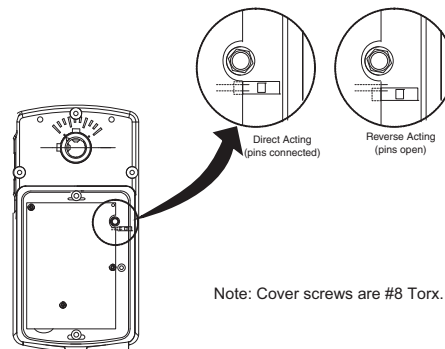

Figure-9 RA/DA Jumper Setting for Proportional Models.

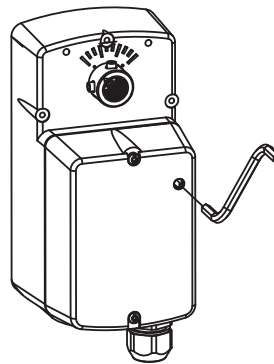

Figure-10 Location of Manual Override.

MANUAL OVERRIDE OPERATION

When necessary, the actuator's output shaft can be repositioned using the manual override mechanism (Figure-10) as follows:

1. Disconnect power from the actuator. Spring return models will fully return to their normal position. Non-spring return models will remain in position.
2. Insert the crank in the product. Without pushing in on the crank, rotate the manual override crank in the direction shown by the arrow on the product label until the actuator rotates to the desired position. Push in until the mechanism locks in position. Non-spring return models do not have the locking feature.
3. If you desire to reposition a spring return actuator manually from a locked position, turn crank 1/8 turn counterclockwise and pull out to release. Adjust position as desired.
4. If you desire to reposition a non-spring return actuator manually, turn the crank in either direction as needed until you reach the desired position.

Caution:

- Only use manual override when the actuator drive motor is not powered.
 - Engaging the manual override when the actuator is powered will cause damage to the gears.
 - Using power tools to adjust the override will cause damage to the gears.
 - Avoid manually repositioning the actuator beyond its adjustable travel limit setting.
-

Damper Mounting

Mx4D-xxxx-xxx Schneider Electric DuraDrive Series Rotary Damper Installation

Caution: Do not drill additional holes in the actuator body. Pre-drilled holes are located on gear plate side to accept #8-32 thread-forming screws for mounting accessories.

Note: The Mx4D-xxxx-xxx rotary actuators mount on shafts up to 1/2" diameter. Two set screws secure the actuator to the shaft.

Move the damper to its normal position. Verify the controller action is set to match the damper application.

Spring return models can be mounted from top or bottom. When mounting from the top, use AM-772 bracket. See Figure-12.

Normally closed damper: when damper is closed, actuator position indicator should be at 0°. When damper is open, actuator position indicator should be at 90°.

Normally opened damper: when damper is open, actuator position indicator should be at 0°. When damper is closed, actuator position indicator should be at 90°.

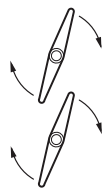
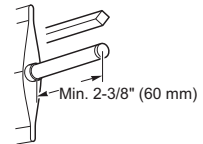

Shaft Rotates
Clockwise
To Open

This step determines
shaft rotation. Linkage
may change damper direction.



Shaft Rotates
Counterclockwise
To Open

Figure-11 Rotary Damper Position.

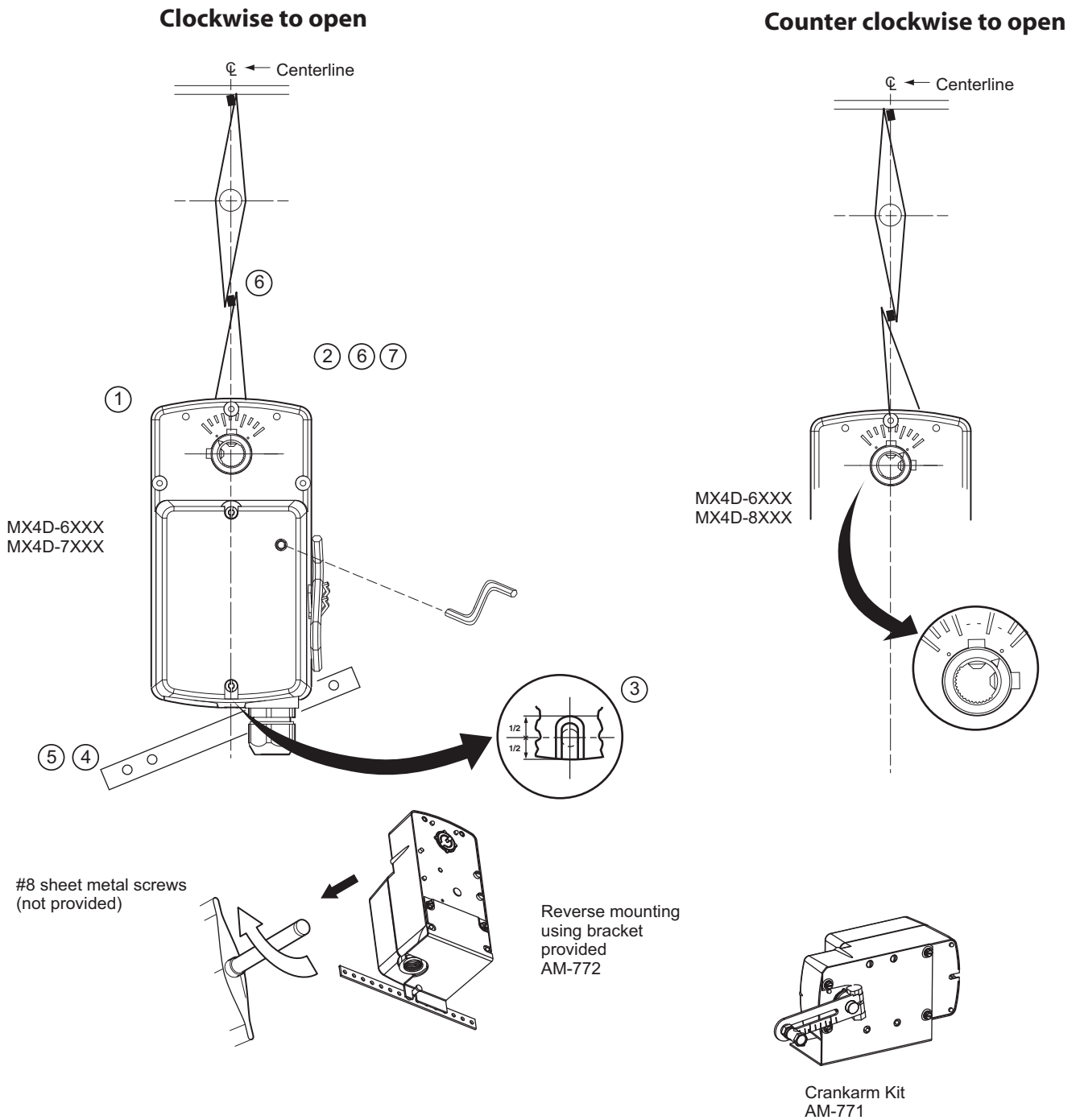

Figure-12 Shaft Installation.

1. Slide actuator over damper shaft.
2. To set a damper preload of 5°, use manual crank to position the actuator 2 full turns from the desired damper closed position. On spring return models, lock the crank in position. See Manual Override Operation, page 10.
3. Hand tighten clamping set screws using 1/8" hex wrench.
4. Center the anti-rotation bracket in the slot and drill holes for two mounting screws.
5. Insert anti-rotation bracket mounting screws and tighten.
6. Tighten the two shaft set screws evenly to 50 to 60 in-lb (5.7 to 6.8 Nm) using a 1/8" hex wrench.

Installation Mx4D-xxxx-xxx Actuators on 1/2" to 3" Schneider Electric DuraLynx Ball Valves

Install the actuator onto the ball valve according to Figure-16.

Note: If space constraints do not allow the actuator to be installed in the standard position, reposition the mounting plate before mounting the actuator.

The valve should be mounted in a weather-protected area, in a location that is within the ambient temperature limits of the actuator. The installation of the actuator assembly should provide clearance on all sides to allow for any maintenance that may be needed (see Figure-13 thru Figure-15).

1. Follow the general piping practices.
2. Apply pipe sealant sparingly to all but the last two threads of a properly threaded, reamed, and cleaned pipe. Make sure the pipe chips, scale, etc. do not get into the pipe since this material may lodge in the valve seat and prevent proper operation of the valve. The valve must be piped with an inlet and an outlet.
3. Start the joint hand-threading the pipe into the valve. If the thread alignment feels normal, continue to turn the pipe by hand as far as it will go.
4. Use a pipe wrench to fully tighten the pipe to the valve.

Caution: Do not over-tighten the pipe, which may cause stripped threads. Avoid twisting or crushing the valve while tightening the pipe.

5. Insulate only the valve body and associated piping. Do not insulate the actuator.
6. In chilled or cold water systems where the environment is humid, use a drip pan under the valve to catch condensate.

Caution: The Schneider Electric DuraDrive actuator is designed to effectively support its own weight. No load or weight should be resting on the actuator. Long term damage may occur to the actuator, mounting connection, or valve.

- Do not insulate the actuator/linkage. Doing so will result in excess heat buildup within the actuator.
 - For non-steam applications the ball valve assembly must be mounted so the actuator is at least 5° above horizontal (Figure-13) to ensure that any condensate that forms will not travel into the mounting bracket or actuator.
 - On steam applications, the ball valve assembly must be mounted approximately 45° from horizontal (Figure-14).
 - Temperature Restrictions: To maintain the maximum ambient temperature 140 °F (60 °C) of the actuator/valve, the maximum allowable fluid temperature should not exceed the 250 °F(121 °C) ball valve maximum rating.
-

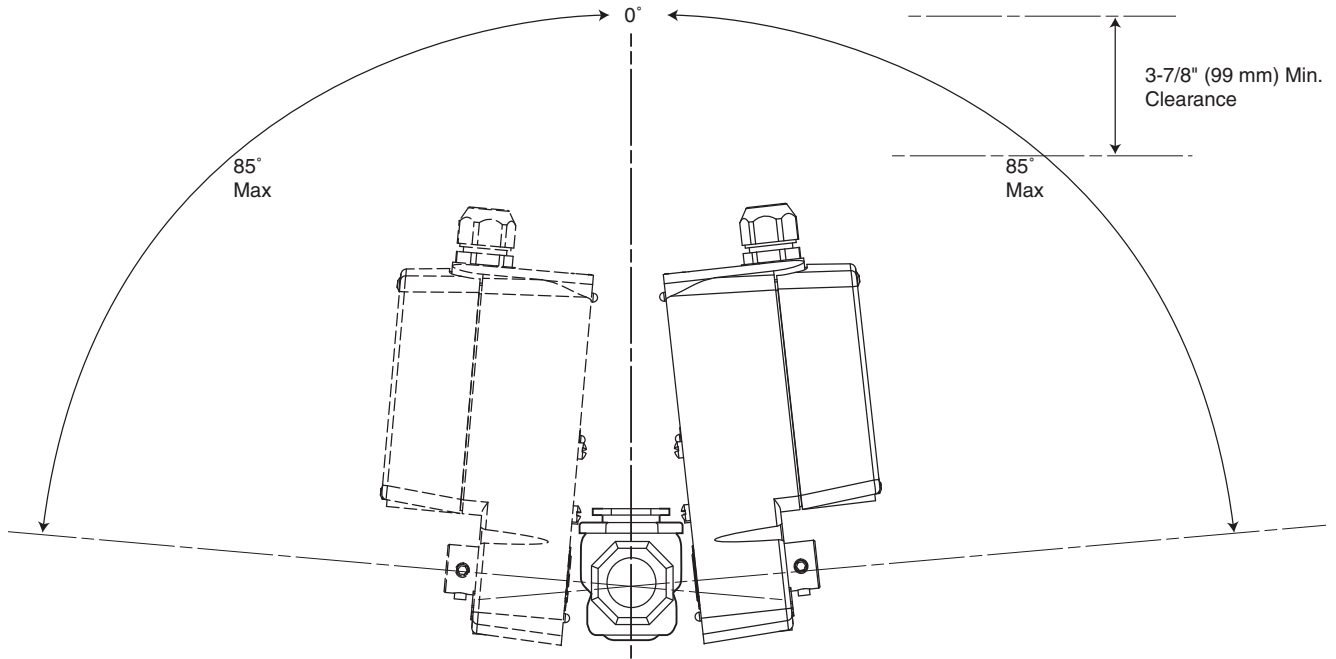

Figure-13 Acceptable Mounting Orientations.

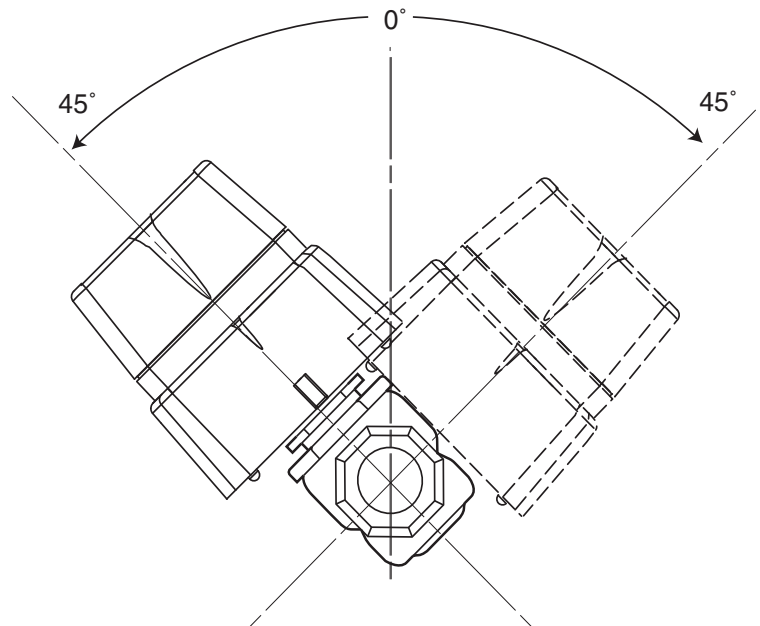

Figure-14 Mounting Orientations for Steam Applications.

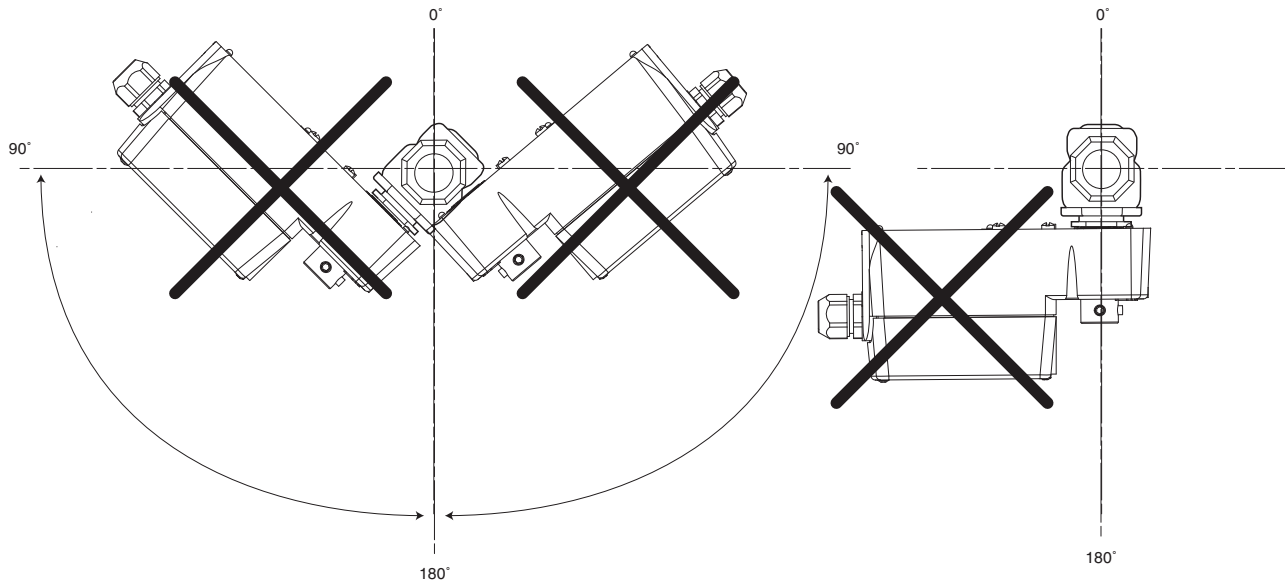

Figure-15 Unacceptable Mounting Orientation.

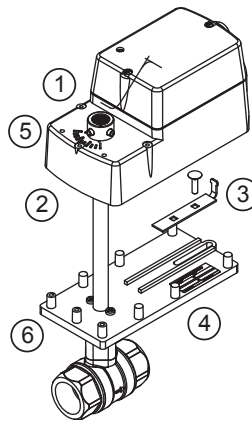
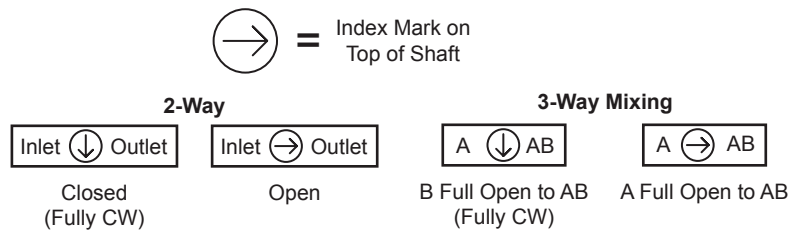

Figure-16 Installation of Mx4D-xxxx-xxx.

Installation

1. For Normally Open 2-Way and Normally Open A to AB 3-Way (Mx4D-7xxx)

Verify that the valve is in the open position (A to AB open on 3-way valves). This position of the ball opening is indicated by the index mark on top of the shaft.

For Normally Closed 2-Way and Normally Closed A to AB 3-Way (Mx4D-8xxx)

Verify that the valve is in the closed position (A to AB closed on 3-way valves). The position of the ball opening is indicated by the index mark on top of the shaft.

For Non-Spring Return 2-Way and 3-Way (Mx4D-8xxx)

Verify that the valve is in the desired end of stroke position. The position of the ball opening is indicated by the index mark on top of the shaft. Verify that the actuator is at the desired end of stroke position. Slide the actuator straight down over the valve shaft and onto the mounting plate.

2. Align the actuator with the mounting plate, then slide the anti-rotation clip half-way into the slot on the bottom of the actuator.
3. Tighten the wing nut to secure the anti-rotation clip in place. Be careful not to over-tighten the wing nut.
4. Using a 1/8" hex wrench, evenly tighten the two setscrews to 50 to 60 in-lb (5.7 Nm to 6.8 Nm).
5. To reposition Base:
 - a. With actuator removed, remove screws.
 - b. Lift mounting plate while holding valve stem in position.
 - c. Rotate base in 45 degree increments.
 - d. Replace screws after reseating base in position.

Wiring Requirements

Control Leads

See Table-6 for power wiring data. Refer to Figure-1 through Figure-8 for typical wiring.

Table-5 Power Wiring.

Actuator Voltage	Part Number	Maximum Wire Run—ft. (m)					
		12 AWG	14 AWG	16 AWG	18 AWG	20 AWG	22 AWG
24 Vac 20 to 30 Vdc	MA4D-7033	1744	1097	690	434	273	216
	MA4D-8033	(532)	(534)	(210)	(132)	(83)	(66)
	MF4D-7033	1308	822	517	325	205	162
	MF4D-8033	(399)	(251)	(158)	(99)	(62)	(49)
	MS4D-7033	1458	917	577	363	228	181
	MS4D-8033	(444)	(279)	(276)	(111)	(70)	(55)
	MF4D-6083	1508	948	596	375	236	187
		(459)	(289)	(182)	(114)	(72)	(57)
	MS4D-6083	1710	1075	676	425	268	212
		(521)	(328)	(206)	(130)	(82)	(65)
	MF4D-6043	2021	1271	799	503	316	251
		(616)	(387)	(244)	(153)	(96)	(76)
	MS4D-6043	2118	1331	837	527	331	263
		(645)	(406)	(255)	(161)	(101)	(80)

CHECKOUT

With the correct control signals applied, power the actuator. Observe movement of the output shaft to check for proper operation. If a spring return model, removing power should cause the actuator to spring return to its rest position. If problems are encountered, check the suggestions below.

Note: Check that the transformer(s) are sized properly.

- If a common transformer is used with multiple actuators, make sure that polarity is observed on the secondary. This means connecting all black wires to one leg of the transformer and all red wires to the other leg of the transformer.
- If multiple transformers are used with one control signal, make sure all black wires are tied together and tied to control signal negative (-).
- If the controller uses a full-wave power supply and does not provide isolated outputs, a separate transformer is required to power the actuator.

THEORY OF OPERATION

The MA series actuators provide two position spring return operation. They are equipped with a mechanical spring return mechanism. When power is applied, the actuator moves to its powered position, at the same time tensing the spring return safety mechanism. When power is removed, the spring returns the actuator to its normal position (retracted). The spring return system provides consistent close-off for sensitive damper or valve applications.

MA series two position actuators use a brush DC motor controlled by on-board electronics. When the actuator encounters a stall or end of travel position, the motor current is automatically reduced, preventing damage to the actuator or motor.

MF or MS series floating or proportional actuators use a brush DC motor which is controlled by a microprocessor. The microprocessor supplies the intelligence to provide a constant speed and to know the actuators exact position. The microprocessor monitors and controls the DC motors rotation and provides a digital rotation sensing function to prevent damage to the actuator in a stall condition.

All actuators may be stalled anywhere in their normal rotation without the need of mechanical end switches.

MAINTENANCE

Regular maintenance of the total system is recommended to assure sustained optimum performance. The Linear series actuators are maintenance free.

FIELD REPAIR

None. Replace with a functional actuator.

DIMENSIONAL DATA

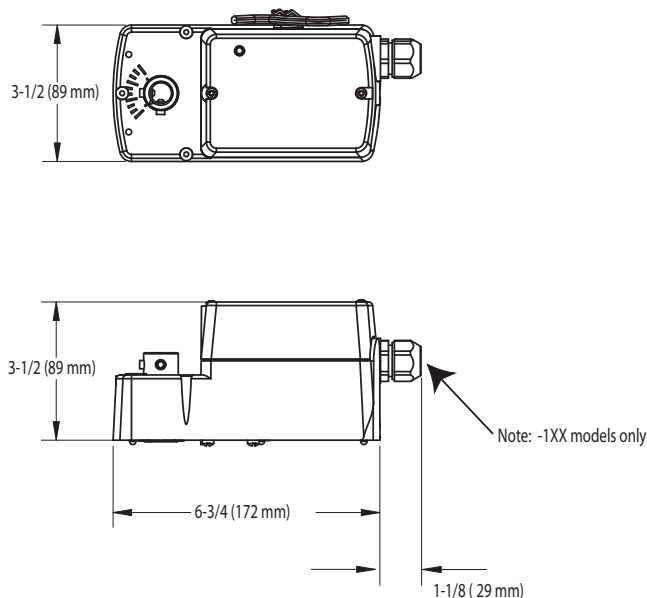

Figure-17 Mx4D-xxxx-xxx Spring Return Valve Actuator Dimensions.

On October 1st, 2009, TAC became the Buildings business of its parent company Schneider Electric. This document reflects the visual identity of Schneider Electric, however there remains references to TAC as a corporate brand in the body copy. As each document is updated, the body copy will be changed to reflect appropriate corporate brand changes.

Copyright 2010, Schneider Electric
All brand names, trademarks and registered trademarks are the property of their respective owners. Information contained within this document is subject to change without notice.

Schneider Electric
1354 Clifford Avenue
P.O. Box 2940
Loves Park, IL 61132-2940

www.schneider-electric.com/buildings

Schneider
Electric